

PROFESSIONAL 88-108MHZ ANTENNA

Ramsey Electronics Model No. TM100

Here's the ultimate radio antenna for your micro-power transmitters and high sensitivity receivers. Maximum power radiation is assured by proper impedance matching and computer design. Greatly increases transmission range! Use what the professionals use, step up to the pump and increase your coverage!

- **Broadband design for full FM broadcast band coverage**
- **75 ohm cable connections for easy hookup and low cost**
- **Simple, heavy duty PVC construction for a durable antenna that will last for years and years**
- **Designed for use with either transmitters or receivers**
- **Helps to increase transmission distance by providing a better radiator than just "hanging wires"**
- **Reduces hum problems by reducing reflected RF power into micro-transmitters**
- **Mountable in either horizontal or vertical position for easy polarization selection**



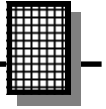

RAMSEY TRANSMITTER KITS

- FM100B Professional FM Stereo Transmitter
- FM25B Synthesized Stereo FM Transmitter
- MR6 Model Rocket Tracking Transmitter
- TV6 Television Transmitter

RAMSEY RECEIVER KITS

- FR1 FM Broadcast Receiver
- AR1 Aircraft Band Receiver
- SR2 Shortwave Receiver
- SC1 Shortwave Converter

RAMSEY HOBBY KITS

- SG7 Personal Speed Radar
- SS70A Speech Scrambler
- BS1 "Bullshooter" Digital Voice Storage Unit
- AVS10 Automatic Sequential Video Switcher
- WCT20 Cable Wizard Cable Tracer
- LC1 Inductance-Capacitance Meter

RAMSEY AMATEUR RADIO KITS

- DDF1 Doppler Direction Finder
- HR Series HF All Mode Receivers
- QRP Series HF CW Transmitters
- CW7 CW Keyer
- CPO3 Code Practice Oscillator
- QRP Power Amplifiers

RAMSEY MINI-KITS

Many other kits are available for hobby, school, Scouts and just plain FUN. New kits are always under development. Write or call for our free Ramsey catalog.



TM100 FM ANTENNA INSTRUCTION MANUAL

Ramsey Electronics publication No. MTM100 Revision 1.1c, April 2008
First printing: May, 1996 MRW

COPYRIGHT 2008 by Ramsey Electronics, LLC 590 Fishers Station Drive, Victor, New York 14564. All rights reserved. No portion of this publication may be copied or duplicated without the written permission of Ramsey Electronics, LLC Printed in the United States of America.

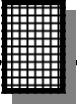

KIT ASSEMBLY AND INSTRUCTION MANUAL FOR

TM100 TRU MATCH FM BAND ANTENNA

TABLE OF CONTENTS

Introduction	4
How Does It Work?	4
Learn As You Build	5
Parts List	7
Construction	8
Testing.....	15
Setup	16
Ramsey Kit Warranty	19



RAMSEY ELECTRONICS, LLC
590 Fishers Station Drive
Victor, New York 14564
Phone (585) 924-4560
Fax (585) 924-4555
www.ramseykits.com

INTRODUCTION TO THE TM100

At Ramsey Electronics we are constantly bombarded with questions on how to get the micro power transmitters to go as far as possible without worry about FCC rules being broken. Here is the answer all you callers and others interested in getting the most out of the FM micro-transmitters. We have come up with a sturdy, easy to build folded dipole antenna with wide band characteristics perfect for transmitting or receiving.

HOW DOES A FOLDED DIPOLE ANTENNA WORK?

A folded dipole antenna is a pair of wires that are suspended between two points. The wire is cut to a specific length, and is fed in the middle with a radio frequency (RF) signal. In our case the folded dipole has an impedance of around 300 ohms, while we are using 75 ohm cable to feed it. We use what is called a matching transformer to convert the impedance from 75 ohms to 300 ohms, which also gives us a better bandwidth where the antenna is efficient at. We also add a ferrite choke core on the coaxial cable to prevent radiation along the coax feed line. This little core really does the trick in providing a proper match to your receiver or transmitter.

As an RF signal is applied to a piece of wire, both an electric and a magnetic field is set up around the wire. These waves propagate through the air (or ether!) without limit. As these magnetic and electric fields reach another station's antenna (or about any other metal object in its path) the exact reverse effect takes place on our antenna that our RF signal did. The rapidly changing fields produce an RF current that your receiver can detect.

Although it is impossible to actually see the waves coming off of a dipole, we can try to visualize it to understand it better. Take a piece of paper and push a pen or pencil through the center. Hold it up in front of you. Let's pretend that the pencil represents our antenna, and the paper represents where our signal is concentrated. As you can see, most of the radiation is given off at a 90 degree angle to the antenna, with very little radiation occurring parallel to the pencil. It is this property that makes the dipole directional. Another advantage is that the radiation is at all angles around the wire, causing the antenna to cover all directions.

If you have any questions, there are many excellent books on antennas available at any good electronics store. The classic ARRL Radio Amateur Handbook is also an excellent resource on antennas.

RAMSEY “LEARN-AS-YOU-BUILD” ASSEMBLY STRATEGY

Be sure to read through all of the steps, and check the boxes as you go to be sure you didn't miss any important steps. Although you may be in a hurry to see results, before you switch on the power check all wiring and capacitors for proper orientation. Also check the board for any possible solder shorts, and/or cold solder joints. All of these mistakes could have detrimental effects on your kit - not to mention your ego!

Kit building tips:

Use a good soldering technique - let your soldering iron tip gently heat the traces to which you are soldering, heating both wires and pads simultaneously. Apply the solder on the iron and the pad when the pad is hot enough to melt the solder. The finished joint should look like a drop of water on paper, somewhat soaked in.

Mount all electrical parts on the top side of the board provided. This is the side that has little or no traces on it. When parts are installed, the part is placed flat to the board, and the leads are bent on the backside of the board to prevent the part from falling out before soldering (1). The part is then soldered securely to the board (2-4), and the remaining lead length is then clipped off (5). Notice how the solder joint looks on close up (6).

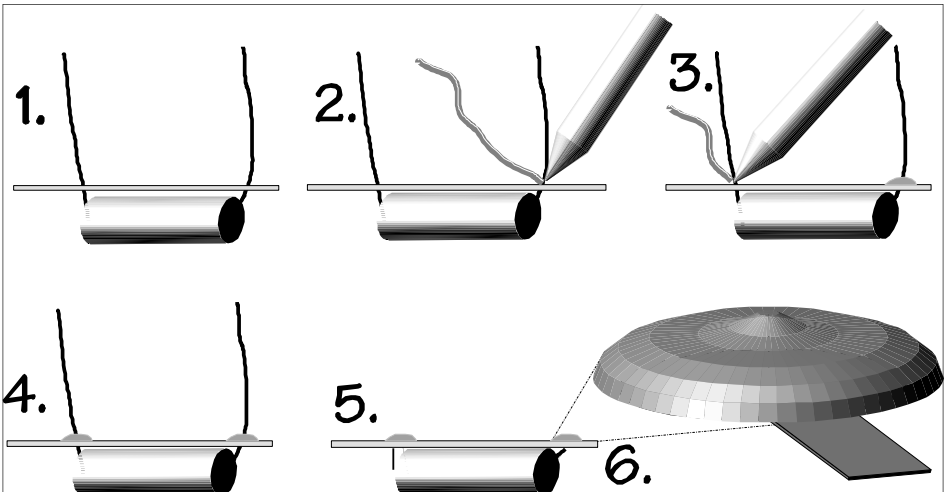

Since this is a “professional” antenna, we sincerely hope you put this together in a professional manner. This project will not work as well as you wished if you just slap it together without following good assembly techniques, and follow all instructions. If you have any questions with an assembly step, give us a call at the factory instead of jumping to conclusions, we will be happy to help you with any problems.

This is a mixed signal project meaning there is digital, audio, and RF circuitry all in one unit. As with all RF circuitry, we want to mount the parts AS LOW AS POSSIBLE to the board. A 1/4” lead length on a part not mounted close to the board can act as an inductor or an antenna, causing all sorts of problems in your circuit.

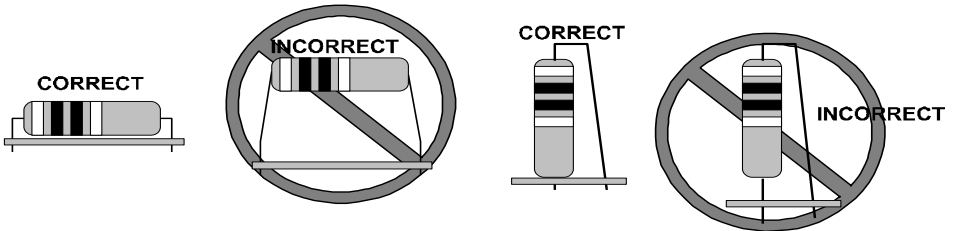

For each part, our word "Install" always means these steps:

1. Pick the correct part value to start with.
2. Insert it into the correct PC board location, making sure the part is mounted flush to the PC board unless otherwise noted.
3. Orient it correctly, follow the PC board drawing and the written directions for all parts - especially when there's a right way and a wrong way to solder it in. (Diode bands, electrolytic capacitor polarity, transistor shapes, dotted or notched ends of IC's, and so forth.)
4. Solder all connections unless directed otherwise. Use enough heat and solder flow for clean, shiny, completed connections.

Keeping this in mind, lets begin by sorting out our components and cross-checking them against the parts list to make sure we have received everything.

NOTE TO NEWCOMERS: If you are a first time kit builder you may find this manual easier to understand than you may have expected. Each part in the kit is checked off as you go, while a detailed description of each part is given. If you follow each step in the manual in order, and practice good soldering and kit building skills, the kit is next to fail-safe. If a problem does occur, the manual will lead you through step by step in the troubleshooting guide until you find the problem and are able to correct it.

RAMSEY TM100 PARTS LIST

Included

- 15 Plastic wire tie wraps
- 5 3/16" ID, 1 1/4" OD fender washers
- 1 54" Piece of Ladder-line twin lead antenna cable
- 1 3' Piece of RG174U thin lead coax
- 1 F Connector and hardware
- 3 1" schedule 40 PVC endcaps
- 4 1" x 12 5/8" schedule 40 PVC pipe pieces
- 2 1" x 10" schedule 40 PVC pipe pieces
- 1 1" 90 degree schedule 40 elbow
- 2 1" schedule 40 couplers
- 1 1" schedule 40 'T' connector
- 1 F connector PCB (Smaller)
- 1 Ferrite choke core for thin coax (1 inch long)
- 1 Ferrite core for matching balun (1/4" long)
- 1 3" piece of bus wire
- 1 9" piece of #30 Enamel

Not included but required

- 1 Soldering iron, preferable a pencil type 30-40 Watts
- 1 Small diameter 60/40 solder
- 1 Wire clippers
- 1 Tape measure
- 1 Length of coax cable to connect from receiver or transmitter to the antenna

Not included, Not required

- 1 PVC Pipe cleaner fluid
- 1 Sandpaper
- 1 PVC Glue

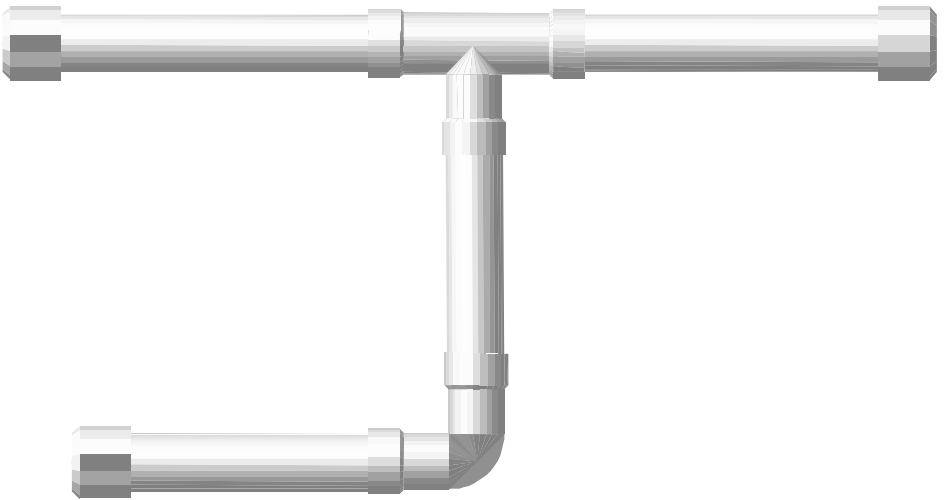

CONSTRUCTION OF THE TM100

- ❑ 1. Cutting the ladder-line twin lead antenna wire. To properly 'size' the antenna, we will want to center our measurements from the center point of the twin lead wire. Then measure from this point out exactly 27 inches in each direction as shown and then cut. You will need some fairly substantial clippers since the wire is copper coated steel (known as copperweld).

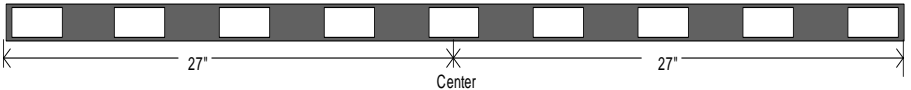

If the wire doesn't have a "window" or cut-out section of plastic insulation in the center, simply use a sharp knife to cut away the plastic to create a clear area similar to the other sections. The size of the window area is not important, just as long as it is at least as big as the other areas.

- ❑ 2. Strip back all four ends of the antenna wire 3/4 of an inch (2 cm).



- ❑ 3. Bend over each wire of the end connections so they meet. You may want to bend them with a pair of pliers since the stiff wire will twist in the insulating material. Solder these ends together securely.



- ❑ 4. Cut one leg of the twin lead wire exactly in the center.

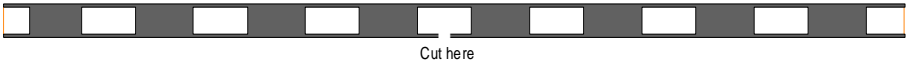

- ❑ 5. Strip back the insulation on either side 3/8 of an inch (1cm).
- ❑ 6. Bend each exposed wire at a right angle in respect to the flat side of the antenna wire.
- ❑ 7. Mount the antenna wire to the component side of the PC board (the side

Twin lead wire viewed sideways

with no solder traces). Bend the twin lead antenna wires down through the PC board holes and over on the other side for a good mechanical connection. Solder both leads tight to the board.

- ❑ 8. Cut the piece of bus wire into three 1" (2.5cm) pieces.

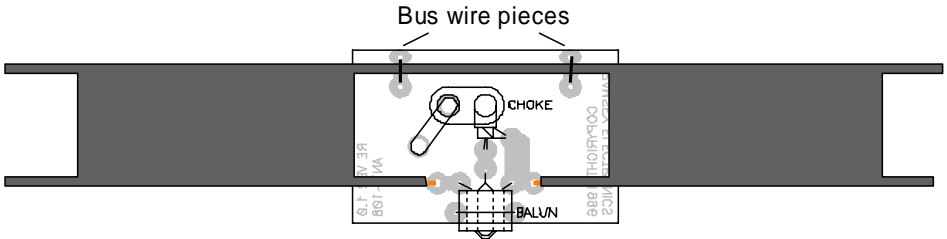

- ❑ 9. Use two of the pieces to hold the antenna wire tight to the PC board as shown.
- ❑ 10. Now we will prepare our coax wire for threading through the board and soldering.
- ❑ 11. Strip back the outside shield 1/2" (1.5 cm) using a sharp blade. Be careful not to cut all the way through the shield wires when doing this.
- ❑ 12. Bunch and twist the shield wires together and solder them into a group.



- ❑ 13. Strip the center conductor insulator back 1/4".
- ❑ 14. Twist the center conductor wires together and solder them into a group.

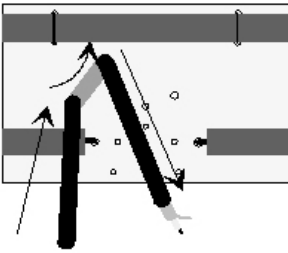

- ❑ 15. Thread one end of the coax through the hole shown from the top side of the board down through the bottom. Pull about 4" (10cm) through.
- ❑ 16. Thread the coax back up through the other hole shown. There should be about 3 1/2" (9cm) before the end.

- ❑ 17. Using the choke (large ferrite bead with two holes large enough for coax), loosely thread the coax up through one side and then back down through the other. There should now be less than an inch (2 1/2cm) of spare wire left over.
- ❑ 18. Solder the center lead into the hole shown directly below the choke.

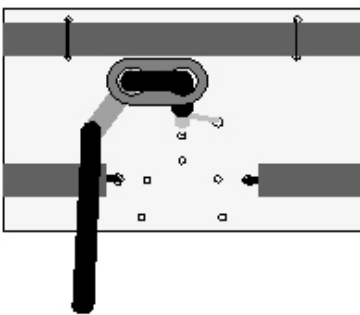
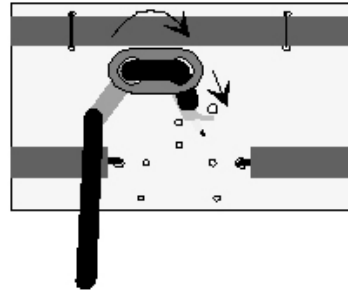

- ❑ 19. Solder the shield conductors to the other hole shown. Be careful to not use too much heat as it will melt the center insulation causing the coax to short out.
- ❑ 20. Before continuing, use an ohmmeter on the 100 ohm to 1000 ohm scale, and make sure that the resistance from the center lead to the shield of the coax registers as an open circuit. If it does not, you will have to redo your coax ends. Testing this with the balun installed will not work, so make sure to test this first before doing the next step!

On the next page we will construct the balun.

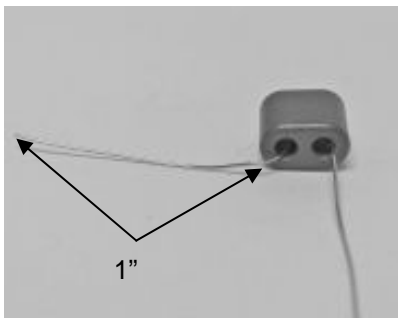

- ❑ 21. Find the nine inch length of #30 enameled wire and the 1/4 inch ferrite core. Keep one inch of wire out of the core and wrap one turn of wire through the core.

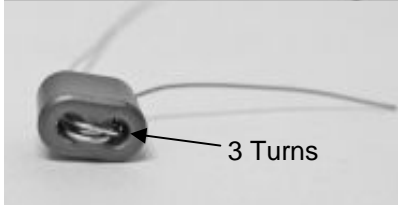

- ❑ 22. Keeping the wire tight continue to wrap two more loops of wire through the core for three total turns.

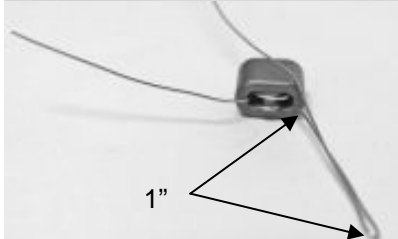

- ❑ 23. Measure one inch of wire from the bottom of the core and fold the wire long wire back on itself.

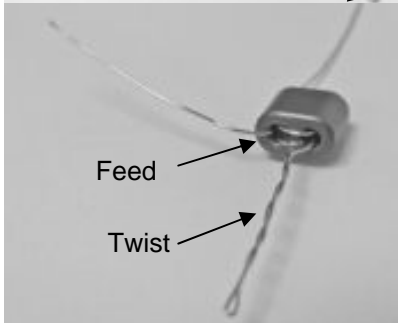

- ❑ 24. Feed the long wire through the core and twist the one inch tail that is left behind. This will be the center tap of the balun. Continue winding the long lead so that the secondary like the primary will contain three complete turns.

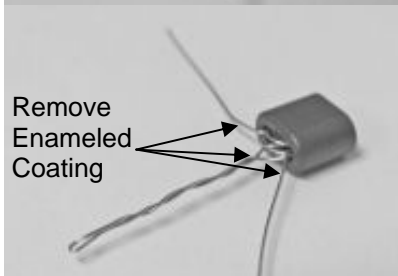

- ❑ 25. Using a knife scrape the enamel off of the three leads. Since this balun's primary and secondary both contain three turns it can be installed in either direction as long as the twisted lead is in the middle hole.

- ❑ 26. Install the balun as shown to the right, inserting the twisted wire into the center hole, while the other wire is soldered into the side holes. Strap down the balun using the remaining piece of bus wire.

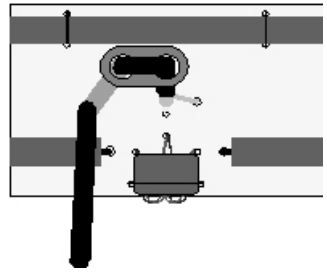

Now we are finished with the actual antenna assembly. If we were to hook it up now we would have a working unit, but first we are going to install the unit into the PVC pipe to keep things together.

MECHANICAL ASSEMBLY

We don't want to glue anything yet until we are absolutely sure everything works, so for now we will press-fit all of the PVC parts together. Press fitting is good enough if you're not planning on setting this up in hurricane conditions.

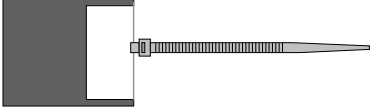
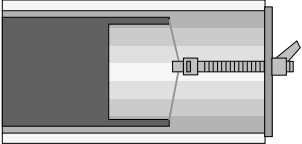
- 23. Using the PVC 'T' connector, slide one end of the twin lead through the top of the 'T'.
- 24. Thread the coax through the leg of the 'T', you may have to slightly bend the ferrite choke core slightly to pass it through the 'T'.
- 25. Tie a tie wrap around each end of the twin lead wire (one on each end of the exposed wire). Do not clip off the ends of the ties as they will be used to pull the antenna tight from the ends to keep it from sliding around inside the pipe. 
- 26. Connect two 12 5/8 inch sections with a 1 inch coupler. Thread the twin lead through the joined (25 1/2 inch) PVC pipe.
- 27. Use a fender washer over the end of the pipe, and insert the tie wrap through the hole. 
- 28. Using another tie wrap, slide it over the end of the first tie wrap so that it pulls the tie wrap connected to the twin lead wire tight.
- 29. Clip the excess tie wrap end off.
- 30. Repeat steps 26 through 29 for the other side of the antenna.

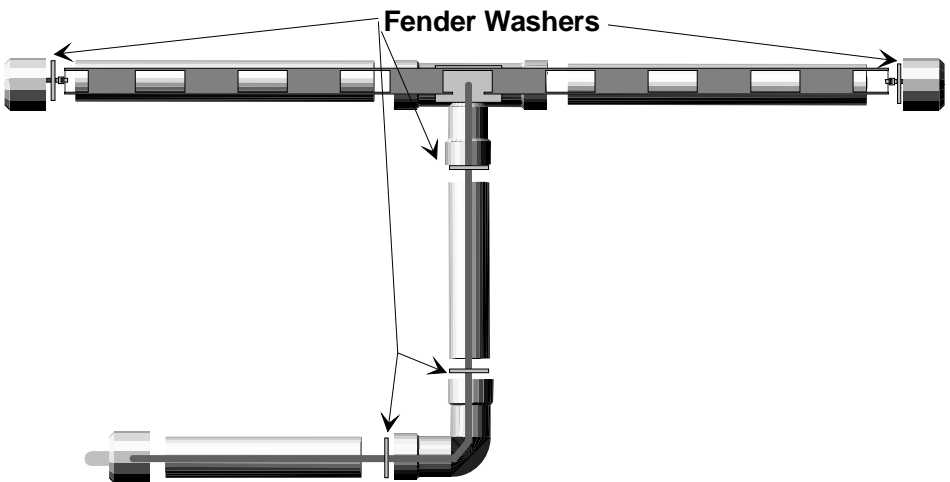

- 31. Use the diagram below to help you with the rest of the assembly.
- 32. Thread the coax through a fender washer. Slide the washer up into the leg of the 'T'.
- 33. Use a tie wrap to hold the fender washer up inside of the leg of the 'T' and keep the coax wire tight to the PC board. You may have to re-arrange a few things on the PC board to make it fit.
- 34. Thread the coax through one of the 10" piece of 1" PVC pipe.
- 35. Slide the PVC pipe into the leg of the 'T', notice how the pipe pins the fender washer into place, and the fender washer keeps things centered.
- 36. Thread another fender washer onto the coax. Use a tie wrap to hold it in place on the end of the pipe.
- 37. Thread the coax through the 90 degree PVC elbow. Place the elbow on the PVC pipe pinning the fender washer in place.
- 38. Thread the last of the fender washers onto the coax. Use a tie wrap to hold the washer in place inside the elbow.
- 39. Thread the last piece of 10" PVC pipe with the coax.

Now we are ready to mount the 'F' style connector. You may choose to use another connector to suit your preferences, if so, feel free to do so. We've

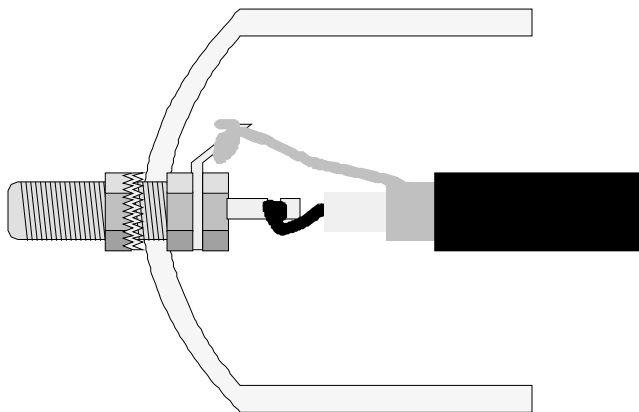

used an 'F' connector since they are very common, easy to attach on coax and work well at these frequencies.

- 40. Mount the 'F' connector in the endcap as shown, using the hardware in the order of: Nut-Lockwasher-PVC end cap-Nut-Solder Lug-F Connector as shown.

- 41. Cut the remaining coax so 3" to 4" (7 cm to 10 cm) is left hanging outside of the antenna assembly.
- 42. Referring to steps 11 - 14, prepare the end of the coax for soldering.
- 43. Bend the solder lug over to reach towards the center pin on the 'F' connector. Solder the braid of the coax to the solder lug.
- 44. Solder the center conductor of the coax to the center solder lug of the 'F' connector.
- 45. Place the endcap onto the pipe.
- 46. Use the two remaining endcaps on the other pipe pieces.

We are all finished with our assembly of the antenna kit. Now we will get into the testing of the antenna so we can be sure it works. Once testing is done you have enough tie wraps to be able to disassemble the antenna, then reassemble it using PVC glue for a more permanent application. Also don't glue the elbow until you are sure of the antenna's final orientation. The elbow allows you to mount the antenna either vertically or horizontally.

TESTING OUT THE TM100

For these next few steps we will need the following things:

- A sensitive receiver (preferably with signal strength meter)
 - A length of coax, the same one you will be using on final hookup.
- 1. Connect a piece of coax with the appropriate connectors between your radio and the antenna.
 - 2. Tune in a weak FM broadcast radio station somewhere in your area.
 - 3. Manually rotate the antenna; the signal strength should vary depending on the orientation of the antenna. (This is about the simplest test we could think of that would verify that the antenna was working!)
 - 4. Check that your antenna works better than a 28" piece of wire used as an antenna.
 - 5. Using an ohmmeter, verify that the resistance measured between the coax center conductor and shield is less than 10 ohms. If greater than 10 ohms, you may have a faulty connector or cold solder joint.
 - 6. If you desire, you may clean or paint your antenna. Clean using a solvent such as acetone and paint using a good grade of enamel paint.

SETTING UP THE TM-100

The best place to mount an antenna is away from large trees and buildings but with a good line of sight to the places you want to reach. This means you will want to mount the antenna up high on a roof or an antenna tower. If you live in an apartment and that is not possible, you will want to mount the antenna in the center of a room for best performance or outside on the porch.

Next you will want to be aware of the signal polarization. If your receiving antenna is vertical, you will also want to mount your transmitting antenna vertically for maximum performance. The same rule goes for horizontal polarization. You will need to experiment a little before you mount the antenna to see which orientation suits you, but the best bet is a vertical polarization (note the orientation of car radio antennas).

If you are planning on mounting the antenna outside, be sure to wait for nice weather. No, the antenna doesn't work better if it has been supercharged with a lightning strike first. Also we're sure you don't want to hear harp music before you're finished installing it. Be sure to stay away from power lines and gutters; they can ruin your day as well.

Many people will use an antenna tripod and mast available at Radio Shack or through ham radio dealers to mount the antenna. Other ways of mounting would be to the chimney, antenna tower, or to a corner of the house (out of sight). Also remember that lightning will strike from the highest points in a given area. It is best to make sure that the antenna is lower than the chimney or a nearby tree. Hopefully mother nature will choose them instead. If in any doubt, install lightning protection on your roof to prevent equipment meltdown.

To enhance performance and reduce the chance of lightning damage you can connect a ground wire from the shield of the coax before it runs into the house to a copper stake driven six feet into the ground. Consult a good antenna book for more details on antenna grounding.

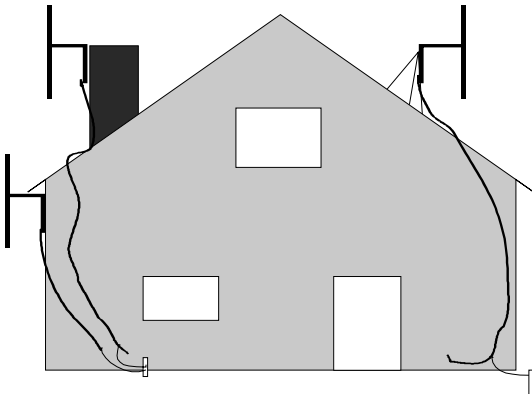

THE RAMSEY KIT WARRANTY

1. GENERAL:

Notice that this is not a "fine print" warranty. We want you to understand your rights and ours too! All Ramsey kits will work if assembled properly. The very fact that your kit includes this new manual is your assurance that prior to release of this kit, a varied group of knowledgeable people have assembled this kit from scratch using this manual. During this process, changes and additions are noted by each assembler and integrated into the final version of the manual...which you have! If you need help, please read through your manual carefully, all information required to properly build and test your kit is contained within the pages! However, customer satisfaction is our goal, so in the event that you do have a problem, please note the following:

2. DEFECTIVE PARTS:

It's always easy to blame a part for a problem in your kit. Before you conclude that a part may be bad, thoroughly check your work. Today's semiconductors and passive components have reached incredibly high reliability levels, and it's sad to say that our human construction skills have not! But on rare occasions a sour component can slip through. All of our kit parts carry the Ramsey Electronics Warranty that they are free from defects for a full ninety (90) days from the date of purchase. Defective parts will be replaced promptly at our expense. If you suspect any part to be defective, please mail it to our factory for testing and replacement. Please send only the defective part(s), not the entire kit. The part(s) MUST be returned to us in suitable condition for testing. Please be aware that testing can usually determine if the part was truly defective or damaged by assembly or usage. Don't be afraid of telling us that you "damaged it" or "burned it out", we're all human and in most cases, replacement parts are very reasonably priced. Remember, our goal for over three decades is to have a happy customer, and we're here to work WITH you, not AGAINST you!

3. MISSING PARTS:

Before assuming a part value is missing, check the parts listing carefully to see if it is a critical value such as a specific coil or IC, or whether a RANGE of values is suitable for the component (such as a "100 to 500 uF capacitor"). Often times, common sense will solve a mysterious missing part problem. If you're missing five 10K ohm resistors and received five extra 1K resistors, you can pretty much be assured that the "1K ohm" resistors are actually the "missing" 10 K parts ("Hum-m-m, I guess the orange band really does look red!") Ramsey Electronics project kits are packed with pride in the USA by our own staff personnel. While separate QC checks are made on all product kits, we too are human, and once in a great while there is a chance something can get through those checks! If you believe we packed an incorrect part or omitted a part clearly indicated in your assembly manual for your Ramsey kit, please contact us with information on the part you need. Contact our Repair Department via telephone, email or writing. Please have your invoice number and date of purchase handy.

4. REFUNDS:

All Ramsey products, kit or factory assembled units have an unconditional 10 day (from the date of purchase) return policy to examine our products. If you are not satisfied for any reason, you may return your unassembled kit with all the parts and instructions, or your factory assembled and tested product, together with your proof of purchase to the factory for a full refund less shipping. The return package should be packed securely. Insurance and tracking is highly recommended. A reminder, this applies to unassembled kits. They must be in the same new condition as received, not partially assembled! Assembled kits cannot be returned for credit. No RMA's are required; simply return to Ramsey Electronics LLC, Attn: Product Returns, 590 Fishers Station Drive, Victor, NY, 14564. If you have any questions, please contact us at 585-924-4560.

5. FACTORY REPAIR OF ASSEMBLED KITS:

Most of us at Ramsey are technically oriented and we do realize that things happen! Even following the best practices, with all of the best intentions, there is that chance that your kit doesn't work when you have completed it. Each manual goes into detailed troubleshooting based on the specific kit to help you troubleshoot the problem. We have found that 95% of returned kits involved wrongly installed components (wrong part or backwards polarity). This section of the warranty assumes you have gone through all those steps, and have now reached the point that you need to send it back.

To qualify for factory repair of customer assembled kits, the following conditions apply:

1. Kits must not be assembled with acid solder flux
2. Kit boards or circuits must not be modified in any manner from the version received
3. Kits must be fully assembled, not partially assembled. Our warranty does not include "finishing" your kit!
4. Must include a full description of the problem encountered including the troubleshooting steps you have already done.
5. Must not include non-standard, non-Ramsey accessories, cases, enclosures, knobs, etc. or any batteries.
6. Must include the minimum repair fee of \$25 USD in the form of check, money order or credit card authorization.
7. Ramsey Electronics, LLC reserves the right to refuse any repair due to excessive errors in construction methods.
8. If, due to customer construction methods, the repair is estimated to exceed the minimum flat rate, Ramsey Electronics, LLC will contact the customer to discuss the repairs needed and to receive authorization and payment for repair prior to repair.
9. In the unlikely case that a defective part is found to be the cause of the problem, the repairs will be made at no-charge to the customer, and any payments received for repair will be returned or credited back to the customer.
10. Properly pack your kit, insure the package, and use a carrier that can be tracked. Ramsey Electronics, LLC is not responsible for any loss or damage in shipment. Send the package together with your repair fee to the return address below. No RMA is required.

6. FACTORY REPAIR FEES:

Please understand that our Tech Support Group personnel are not volunteers! They are a dedicated group of highly trained technicians each configured with a very properly equipped test bench. Upon receipt of a repair, the setup, testing, diagnosis, repair, paperwork, and repacking of your kit requires nearly an hour of their time regardless of the size or complexity of the kit! The minimum repair fee represents ½ hour Tech Support time at \$50/hour USD. We try to keep all kit repairs within the realm of the \$25 flat rate whenever possible...and trust us; we exceed that time spent on most kits received more often than not!

7. CONTACT INFORMATION AND RETURN ADDRESS:

Technical Questions

RAMSEY ELECTRONICS, LLC
Attn: Tech Support
590 Fishers Station Drive
Victor, NY 14564
585-924-4560; 585-924-4886 Fax
techsupport@ramseyelectronics.com

Product Repair & Returns

RAMSEY ELECTRONICS, LLC
Attn: Repairs
590 Fishers Station Drive
Victor, NY 14564
585-924-4560; 585-924-4886 Fax
repairs@ramseyelectronics.com

TRU MATCH FM BAND ANTENNA KIT Quick Reference Page Guide

Introduction	4
How Does It Work?	4
Learn As You Build	5
Parts List	7
Construction.....	8
Testing	15
Setup	16

REQUIRED TOOLS

- Soldering Iron
- Thin Rosin Core Solder
- Needle Nose Pliers
- Small Diagonal Cutters

ADDITIONAL SUGGESTED ITEMS

- Helping Hands Holder for PC Boards
- Desoldering

Price: \$5.00

Ramsey Publication No. MTM100

Assembly and Instruction manual for:

RAMSEY MODEL NO. TM100



RAMSEY ELECTRONICS, LLC
590 Fishers Station Drive
Victor, New York 14564
Phone (585) 924-4560
Fax (585) 924-4555
www.ramseykits.com

<u>TOTAL SOLDER POINTS</u> 10
<u>ESTIMATED ASSEMBLY TIME</u>
Beginner 3 hrs
Intermediate 2 hrs
Advanced..... 1 hrs